

**ISUZU BERPENGALAMAN DENGAN
MESIN COMMON RAIL SEJAK 2011**

ISUZU
ELF
NQR B



**IRIT MAKSIMAL,
MUAT PENUMPANG
OPTIMAL**

**euro4
ready**

*Gambar pada brosur ini hanya ilustrasi, mungkin ada perbedaan dengan aktual kendaraan
**Mesin common rail pada Isuzu Giga sejak tahun 2011

REAL PARTNER. REAL JOURNEY.

SPESIFIKASI TEKNIS

SPESIFIKASI		NQR B
DIMENSI / DIMENSION		
Panjang / Overall Length [OAL]	mm	7,465
Lebar / Overall Width [OW]	mm	2,100
Tinggi / Overall Height [OH]	mm	2,060
Jarak Sumbu / Wheelbase [WB]	mm	4,175
Julur Depan / Front Overhang [FOH]	mm	1,110
Julur Belakang / Rear Overhang [ROH]	mm	2,140
Jarak Terendah ke Tanah / Minimum Clearance [HH]	mm	200
Jejak Depan / Front Tread [AW]	mm	1,680
Jejak Belakang / Rear Tread [CW]	mm	1,650
MESIN / ENGINE		
Model		4HL1-TCS
Tipe / Type		Direct Injection, Commonrail, SOHC, 4 Cylinder, VGS Turbo Intercooler
Sistem Kontrol Emisi		EURO4 with EGR & DOC
Diameter x Langkah / Bore x Stroke	mm	115 X 115
Isi Silinder / Piston Displacement	cc	4,778
Tenaga Maksimum / Maximum Power	PS/rpm	150 / 2,600
Torsi Maksimum / Maximum Torque	Kgm/rpm	41 / 1,400 - 2,600
TRANSMISI / TRANSMISSION		
Model		MY6S
Perbandingan Gigi / Gear Ratio		
	1st	5.979
	2nd	3.434
	3rd	1.862
	4th	1.297
	5th	1.000
	6th	0.759
	Rev	5.701
Perbandingan Gigi Terakhir / Final Gear Ratio		5.125

SPESIFIKASI		NQR B
BERAT / WEIGHT		
Berat Kosong Kendaraan / Curb Weight	kg	2,312
Berat Total Kendaraan / Gross Vehicle Weight [GVW]	kg	8,000
Kapasitas Gardan Depan / Capacity Front Axle	kg	3,000
Kapasitas Gardan Belakang / Capacity Rear Axle	kg	5,000
REM / BRAKE		
Tipe / Type		Hydraulic
Rem Kaki / Service Brake		Hydraulic Brake Booster
Rem Tangan / Hand Brake		Expanding pada transmisi belakang
Sistem Pengereman Gas Buang / Exhaust Brake		Exhaust brake, tuas berada di stir
RODA / TYRE		
Ukuran Ban		7.50-16-14PR
Ukuran Velg		16 X 6.00
SUSPENSI / SUSPENSION		
Depan / Front		Semi elliptical laminated leaf spring dengan shock absorber berdaya ganda
Belakang / Rear		
LAIN-LAIN / OTHERS		
Kapasitas Tangki / Fuel Tank Capacity	litr	100
Radius Putar Minimum / Minimum Turning Radius	m	7.5
Daya Tanjak Maksimum / Maximum Gradeability	%	39
Kecepatan Maksimum / Maximum Speed	km/h	107
Aki / Accu	V-Ah	2 X 12 V - 65 Ah
Alternator	V-A	24 - 80
Kamera Mundur / Reverse Parking Camera		Ada
Audio Head Unit		Ada
APAR (Alat Pemadam Api Ringan)		Ada
Garansi / Warranty		3 Tahun / 100,000 km

* Untuk meningkatkan mutu dan penyesuaian dengan perkembangan teknologi, spesifikasi dapat berubah sewaktu-waktu tanpa pemberitahuan. ** Ilustrasi merupakan contoh sebagian aplikasi di lapangan.

DIMENSI

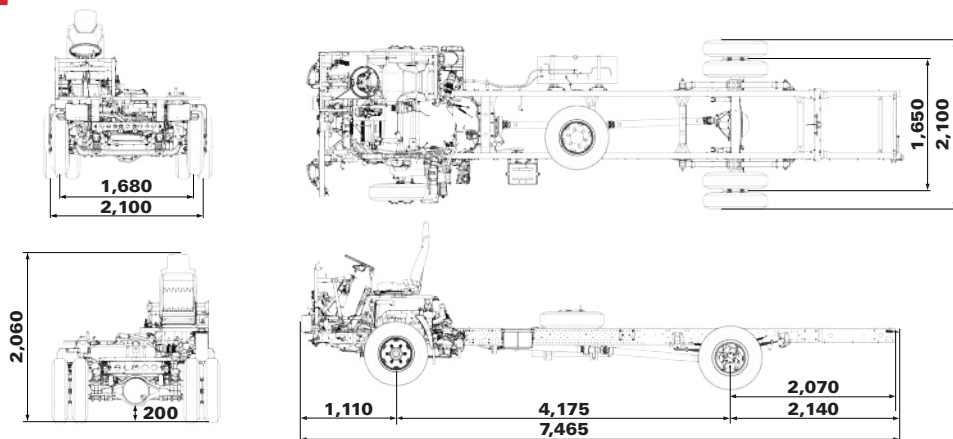

APLIKASI

MEDIUM BUS



SCAN INI
UNTUK
INFORMASI
LEBIH LANJUT

